

SMF SERIES



200 WATT SURFACE MOUNT TRANSIENT VOLTAGE SUPPRESSORS



FEATURES

- * For surface mount application
- * Built-in strain relief
- * Excellent clamping capability
- * Low profile package
- * Fast response time: Typically less than 1.0ps from 0 volt to BV min.
- * Typical I_R less than $1\mu A$ above 10V

MECHANICAL DATA

- * Case: Molded plastic
- * Epoxy: UL 94V-0 rate flame retardant
- * Lead: Solderable per MIL-STD-202, method 208 guaranteed
- * Polarity: Color band denotes cathode end except Bidirectional
- * Mounting position: Any

VOLTAGE RANGE

5.0 to 220 Volts

200 Watts Peak Power

SOD-123

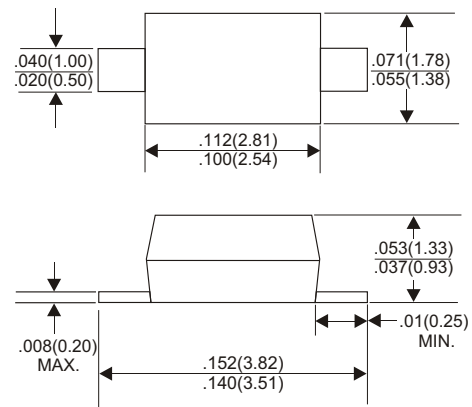

Dimensions in inches and (millimeters)

MAXIMUM RATINGS AND ELECTRICAL CHARACTERISTICS

Rating $25^{\circ}C$ ambient temperature unless otherwise specified.
Single phase half wave, 60Hz, resistive or inductive load.
For capacitive load, derate current by 20%.

RATINGS	SYMBOL	VALUE	UNITS
Peak Power Dissipation with a 10/1000 μs waveform a 8/20 μs waveform	P_{PK}	Minimum 200 Minimum 1000	Watts Watts
Peak Forward Surge Current at 8.3ms Single Half Sine-Wave superimposed on rated load (JEDEC method) (NOTE 1)	I_{FSM}	20	Amps
Maximum Instantaneous Forward Voltage at 25.0A for Unidirectional only	V_F	3.5	Volts
Operating and Storage Temperature Range	T_J, T_{STG}	-55 to +150	$^{\circ}C$

NOTES:

1. 8.3ms single half sine-wave, duty cycle = 4 pulses per minute maximum.

DEVICES FOR BIPOLAR APPLICATIONS

1. For Bidirectional use C Suffix for types SMF5.0A thru SMF220A.
2. Electrical characteristics apply in both directions.

RATING AND CHARACTERISTIC CURVES (SMF SERIES)

FIG.1-PEAK PULSE POWER DERATING CURVE

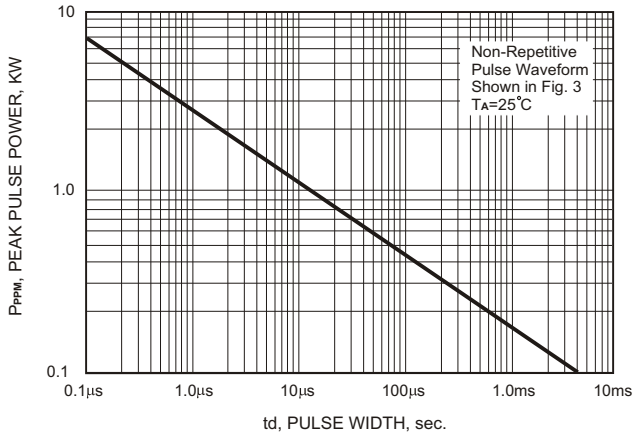

FIG.2-PULSE DERATING CURVE

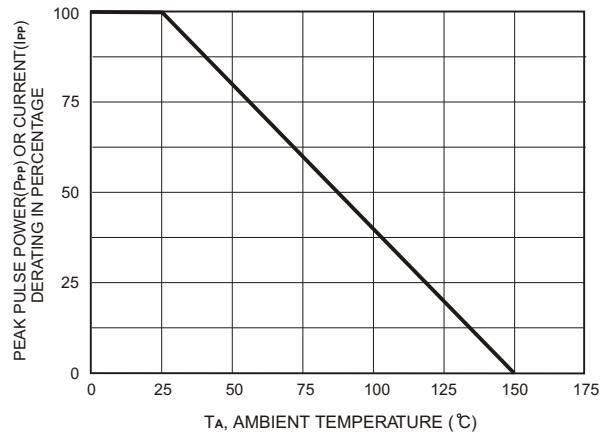

FIG.3-PULSE WAVE FORM

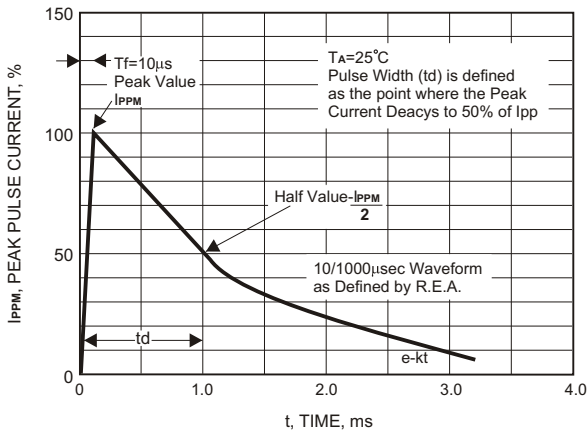

FIG.4-TYPICAL JUNCTION CAPACITANCE

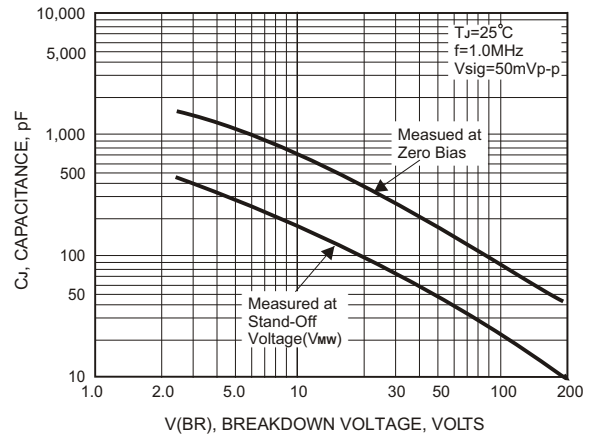

FIG.5-MAXIMUM NON-REPETITIVE PEAK FORWARD SURGE CURRENT

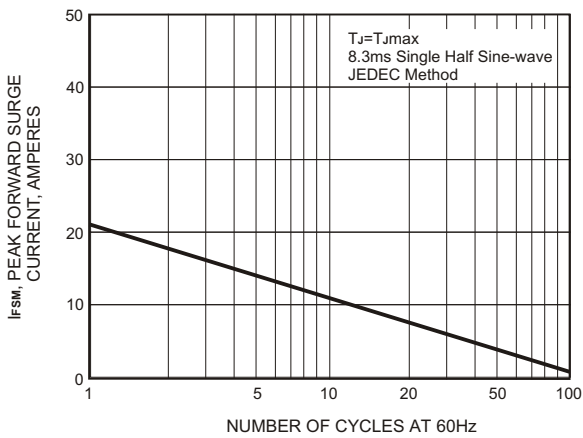
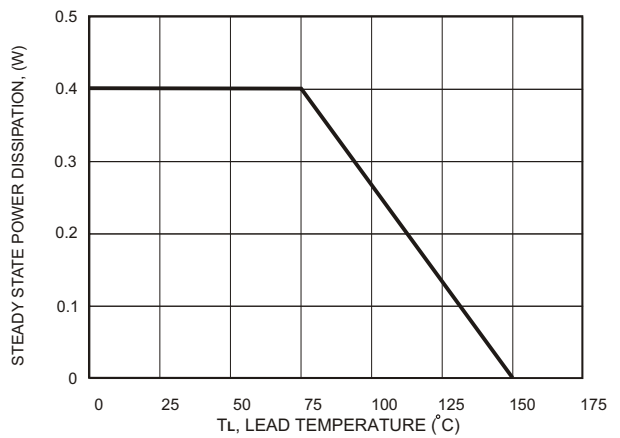

FIG.6-STEADY STATE POWER DERATING CURVE



200 Watt Surface Mount TVS



Part Number (Uni)	Part Number (Bi)	Device Marking Code		Reverse Standoff Voltage	Breakdown Voltage V_{BR} @ I_T			Maximum Reverse Leakage @ V_R	Maximum Peak Pulse Current	Maximum Clamping Voltage @ I_{pp}
		Uni	Bi		V_R (V)	Min (V)	Max (V)			
SMF5.0A	SMF5.0CA	FE	KE	5.0	6.40	7.00	10	400	21.74	9.2
SMF6.0A	SMF6.0CA	FG	KG	6.0	6.67	7.37	10	400	19.42	10.3
SMF6.5A	SMF6.5CA	FK	KK	6.5	7.22	7.98	10	250	17.86	11.2
SMF7.0A	SMF7.0CA	FM	KM	7.0	7.78	8.60	10	100	16.67	12.0
SMF7.5A	SMF7.5CA	FP	KP	7.5	8.33	9.21	1	50	15.50	12.9
SMF8.0A	SMF8.0CA	FR	KR	8.0	8.89	9.83	1	25	14.71	13.6
SMF8.5A	SMF8.5CA	FT	KT	8.5	9.44	10.40	1	10	13.89	14.4
SMF9.0A	SMF9.0CA	FV	KV	9.0	10.00	11.10	1	5	12.99	15.4
SMF10A	SMF10CA	FX	KX	10.0	11.10	12.30	1	5	11.76	17.0
SMF11A	SMF11CA	FZ	KZ	11.0	12.20	13.50	1	5	10.99	18.2
SMF12A	SMF12CA	HE	LE	12.0	13.30	14.70	1	5	10.05	19.9
SMF13A	SMF13CA	HG	LG	13.0	14.40	15.90	1	5	9.30	21.5
SMF14A	SMF14CA	HK	LK	14.0	15.60	17.20	1	5	8.62	23.2
SMF15A	SMF15CA	HM	LM	15.0	16.70	18.50	1	5	8.20	24.4
SMF16A	SMF16CA	HP	LP	16.0	17.80	19.70	1	5	7.69	26.0
SMF17A	SMF17CA	HR	LR	17.0	18.90	20.90	1	5	7.25	27.6
SMF18A	SMF18CA	HT	LT	18.0	20.00	22.10	1	5	6.85	29.2
SMF19A	SMF19CA	HB	LB	19.0	21.10	23.30	1	5	6.54	30.6
SMF20A	SMF20CA	HV	LV	20.0	22.20	24.50	1	5	6.17	32.4
SMF22A	SMF22CA	HX	LX	22.0	24.40	26.90	1	5	5.63	35.5
SMF24A	SMF24CA	HZ	LZ	24.0	26.70	29.50	1	5	5.14	38.9
SMF26A	SMF26CA	JE	ME	26.0	28.90	31.90	1	5	4.75	42.1
SMF28A	SMF28CA	JG	MG	28.0	31.10	34.40	1	5	4.41	45.4
SMF30A	SMF30CA	JK	MK	30.0	33.30	36.80	1	5	4.13	48.4
SMF33A	SMF33CA	JM	MM	33.0	36.70	40.60	1	5	3.75	53.3
SMF36A	SMF36CA	JP	MP	36.0	40.00	44.20	1	5	3.44	58.1
SMF40A	SMF40CA	JR	MR	40.0	44.40	49.10	1	5	3.10	64.5
SMF43A	SMF43CA	JT	MT	43.0	47.80	52.80	1	5	2.88	69.4
SMF45A	SMF45CA	JV	MV	45.0	50.00	55.30	1	5	2.75	72.7
SMF48A	SMF48CA	JX	MX	48.0	53.30	58.90	1	5	2.58	77.4
SMF51A	SMF51CA	JZ	MZ	51.0	56.70	62.70	1	5	2.43	82.4
SMF54A	SMF54CA	XE	NE	54.0	60.00	66.30	1	5	2.30	87.1
SMF58A	SMF58CA	XG	NG	58.0	64.40	71.20	1	5	2.14	93.6
SMF60A	SMF60CA	XK	NK	60.0	66.70	73.70	1	5	2.07	96.8
SMF64A	SMF64CA	XM	NM	64.0	71.10	78.60	1	5	1.94	103.0
SMF70A	SMF70CA	XP	NP	70.0	77.80	86.00	1	5	1.77	113.0
SMF75A	SMF75CA	XR	NR	75.0	83.30	92.10	1	5	1.65	121.0
SMF78A	SMF78CA	XT	NT	78.0	86.70	95.80	1	5	1.59	126.0
SMF80A	SMF80CA	XB	NB	80.0	88.80	97.60	1	5	1.55	129.0
SMF85A	SMF85CA	XV	NV	85.0	94.40	104.00	1	5	1.46	137.0
SMF90A	SMF90CA	XX	NX	90.0	100.00	111.00	1	5	1.37	146.0
SMF100A	SMF100CA	XZ	NZ	100.0	111.00	123.00	1	5	1.23	162.0
SMF110A	SMF110CA	TE	PE	110.0	122.00	135.00	1	5	1.13	177.0
SMF120A	SMF120CA	TG	PG	120.0	133.00	147.00	1	5	1.04	193.0
SMF130A	SMF130CA	TK	PK	130.0	144.00	159.00	1	5	0.96	209.0
SMF140A	SMF140CA	TB	PB	140.0	155.00	171.00	1	5	0.89	224.0
SMF150A	SMF150CA	TM	PM	150.0	167.00	185.00	1	5	0.82	243.0
SMF160A	SMF160CA	TP	PP	160.0	178.00	197.00	1	5	0.77	259.0

200 Watt Surface Mount TVS



Part Number (Uni)	Part Number (Bi)	Device Marking Code		Reverse Standoff Voltage	Breakdown Voltage V_{BR} @ I_T			Maximum Reverse Leakage @ V_R	Maximum Peak Pulse Current	Maximum Clamping Voltage @ I_{pp}
		Uni	Bi		V_R (V)	Min (V)	Max (V)			
SMF170A	SMF170CA	TR	PR	170.0	189.00	209.00	1	5	0.73	275.0
SMF180A	SMF180CA	TT	PT	180.0	200.00	220.00	1	5	0.68	292.0
SMF190A	SMF190CA	TV	PV	190.0	211.00	232.00	1	5	0.65	308.0
SMF200A	SMF200CA	TX	PX	200.0	224.00	247.00	1	5	0.62	324.0
SMF220A	SMF220CA	TZ	PZ	220.0	246.00	272.00	1	5	0.56	356.0